

# PSQ

PS Automation   
Gesellschaft für Antriebstechnik

*We care for actuation.*

## The robust quarter-turn actuator up to 1000 Nm

**All common power supplies:**  
single phase, 3-phase and DC voltage.  
**Suitable for control operations.**  
Protection class IP67  
is standard,  
protection class IP68 is optional

Visible from a  
distance: mechanical  
**position indicator**

Synchronous  
or brake motors with  
fast stop  
for accurate  
**positioning**

Compact, corrosion-  
resistant, robust and  
lightweight  
through high-quality  
**aluminum alloys**

**Torque limits** in  
both directions  
easily set and variable  
between 50% and 100%

Covered  
**mechanical limit  
stops** which can be  
set in a range of  
 $\pm 5^\circ$

**ISO 5211 valve connector**  
and interchangeable drive  
bushing made from sintered  
metal for fast mounting

No switching-over to manual operation  
needed. **The hand wheel** does not rotate  
during the automated operation but is  
always ready for operation

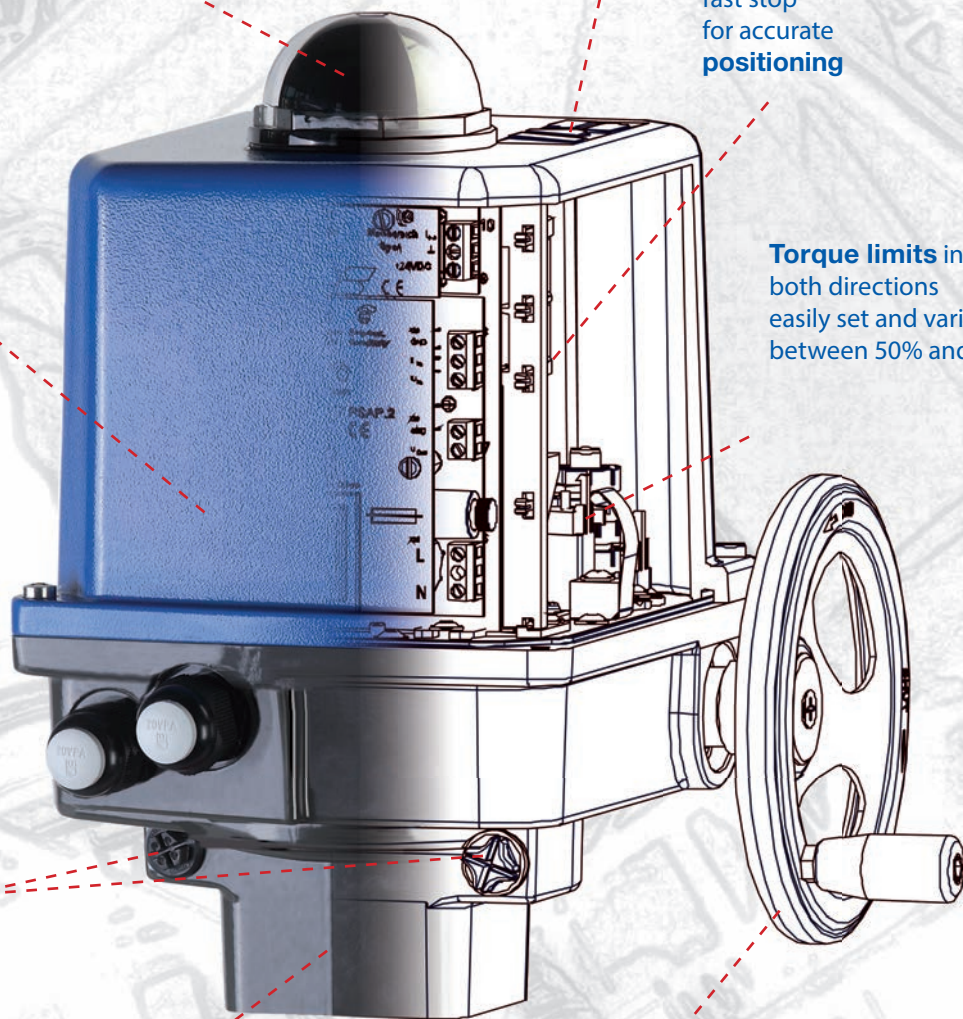

## Technical Data

PSQ		PSQ102 Standard	PSQ102 150 Nm) <sup>1</sup>	PSQ202 Standard	PSQ202 300 Nm) <sup>1</sup>	PSQ502 Standard	PSQ502 600 Nm) <sup>1</sup>	PSQ702	PSQ1002
Switching Torque	Nm	130	150	250	300	500	600	700	1000
Modulating Torque	Nm	65	75	125	150	250	300	350	500
Angle of Rotation	°	90 ± 5							
Handwheel Turns	/90°	18							
Valve Flange acc. to ISO 5211		F05 / F07	F05 / F07	F07 / F10	F07 / F10	F10 / F12	F10 / F12	F10 / F12	F12 / F14
Enclosure acc. to EN 60529		IP67							
Ambient Temperature	°C	-20 to +80°C, control operations up to +60°C							
Weight	kg	7	7	13	13	27	27	27	27
Operating Time/90°	s	8 - 57	32	20 - 69	69	29 - 93	93	29 - 93	29 - 93
Power Supply	V	230 VAC 1~ 115 VAC 1~ 24 VAC/DC 400 VAC 3~							

<sup>1)</sup> only for 230 VAC

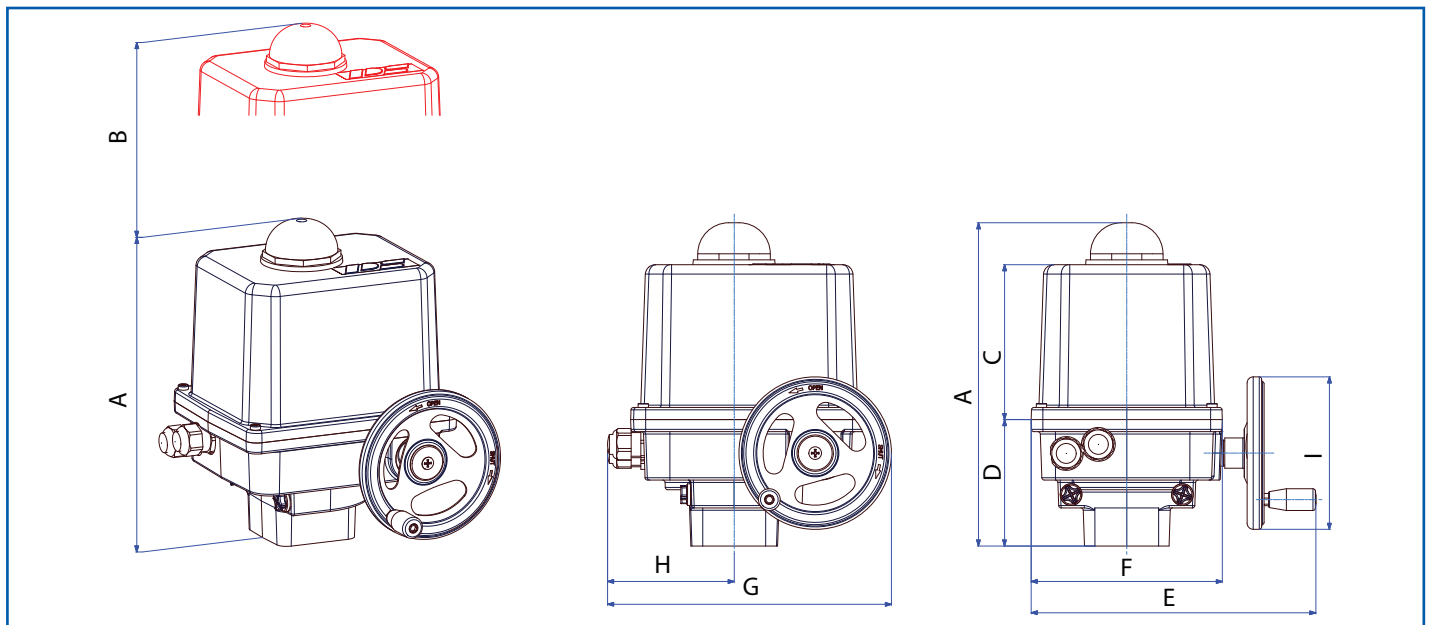

Dimensions	A	B	C	D	E	F	G	H	I
PSQ102	267	161	128	104.5	237	158	241	111	125
PSQ202	355	228	194	122.5	307	185	289	109	200
PSQ502/702	416	240	198	171.5	358	235	337	128	200
PSQ1002	416	240	198	171.5	289	235	362	128	250

**PS Automation GmbH**  
**Gesellschaft für Antriebstechnik**

Philipp-Krämer-Ring 13 • D-67098 Bad Dürkheim  
Tel.: +49 (0) 63 22-60 03-0 • Fax: +49 (0) 63 22-60 03-20  
info@ps-automation.com • www.ps-automation.com

**Engineered and Made in Germany**

